

ORDINANCE NO. 4755

AN ORDINANCE making an additional appropriation in the amount of \$11,962 to the Cedar Hills Construction Fund from the Miscellaneous Trusts Fund, Cedar Hills Alcoholism Account No. 06774 to complete the Activities Building at the Cedar Hills Alcoholism Treatment Center; amending the 1980 Capital Improvement Budget and Program and amending Ordinance No. 4597, Section 74, Attachment No. 1, as amended.

BE IT ORDAINED BY THE COUNCIL OF KING COUNTY:

SECTION 1. There is hereby approved and adopted an appropriation in the amount of \$11,962 to the Cedar Hills Construction Fund from the Miscellaneous Trusts Fund, Cedar Hills Alcoholism Account No. 06774, to complete the Activities Building at the Cedar Hills Alcoholism Treatment Center; C.I.P. Project No. 004072.

SECTION 2. Ordinance No. 4597, Section 74, as amended, is hereby amended to read as follows:

From the several Capital Improvement project funds there are hereby appropriated and authorized to be disbursed the following amounts for the specific projects identified and contained in Attachment No. 1 and Section 73, of this ordinance.

Cedar Hills Construction	(\$102,409)	<u>\$114,371</u>
--------------------------	------------------------	------------------

PROVIDED THAT:

All provisos adopted by the Council in Ordinance No. 4597, as amended, shall be fulfilled.

1 SECTION 3. The project information sheet attached hereto is
2 adopted to amend and revise the 1980 Capital Improvement Budget
3 and Program; amending Ordinance No. 4597, Section 74, Attachment
4 No. 1, as amended.

5 INTRODUCED AND READ for the first time this 25th
6 day of February, 1980.

7 PASSED this 3rd day of March, 1980.

8 KING COUNTY COUNCIL
9 KING COUNTY, WASHINGTON

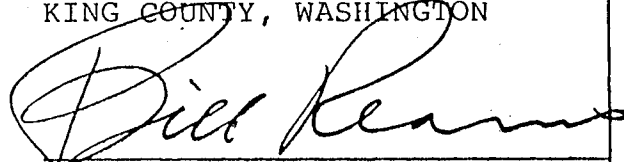
10 
11 Chairman

12 ATTEST:

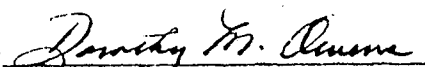
13
14 
15 DEPUTY Clerk of the Council

16 APPROVED this 11th day of March, 1980.

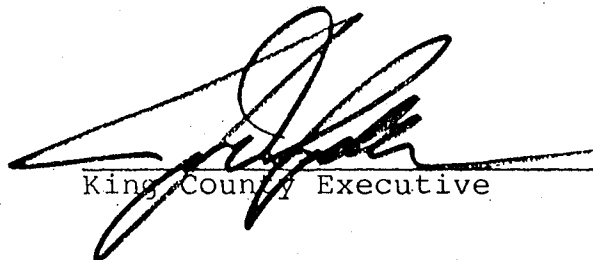
17
18 
19 King County Executive

20
21
22
23
24
25
26
27
28
29
30
31
32
33

Project: 004072 Cedar Hills Activities Building

Description:

Council District: No. 9
CIP Planning Area: Tahoma

Project involves the design and construction of an approximate 2530 Sq. Ft. wood framed one-story building including two restrooms, two offices, and two open space multipurpose rooms. This facility will be used primarily to support a "light" power tool vocational training program for patients at the Cedar Hills Alcoholism Treatment Center.

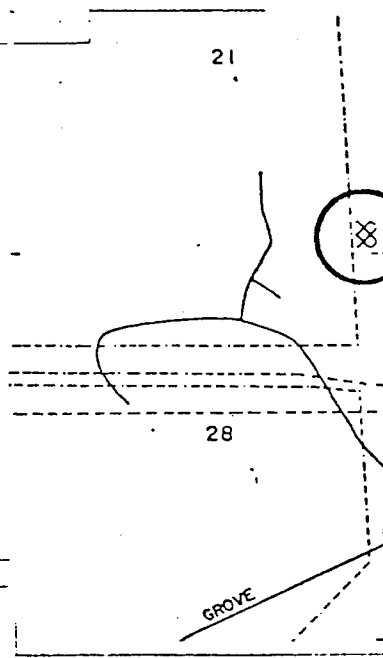

Project Comparison 1979-1984 vs. 1980-1985

No Changes To Be Abandoned To Be Merged Total Cost Change Site Change
 New Revenue Change Scope Change Schedule Change

Cost Data:

Status:

Original Cost Estimate - 1978 \$62,282 Project scheduled for completion in 1979.

Project Data:

FUND	000003450 CEDAR HILLS CENTER CONST	DEPARTMENT PRIORITY REQUEST 000	RE
DEPARTMENT	0335 ARCHITECTURE-345/CEDR HLS	LOCATION - CEDAR HILLS ATC	
FUNCTION	56700 ALCOHOLISM	CURRENT PROJECT COST ESTIMATE	
SERVICE	56710 ALCOHOLISM	EXPENDED & APPROPRIATED (INC RECOMMENDED)	
PROGRAM	56711 ALCOHOLISM	FUTURE FUNDING REQUIRED TO COMPLETE PRO	

OPTION	EXPENDITURES TO 12-31-78	EXISTING BUDGET	1980 RECOMMENDED	EXP + BUDGET + RECOMMENDED (A+B+C)	*PROGRAM PROJECTIONS - THOUSANDS OF DOLLARS				
	(A)	(B)	(C)	(A+B+C)	1981	1982	1983	1984	1985 TO
-----EXPENDITURE DATA-----									
PRELIM ENGINEERING	3,117	1,040		4,157	*				
CONSTRUCTION	5,798	75,467	8,899	90,164	*				
CONTINGENCY	6,236		2,644	8,880	*				
ARTISTIC FURNISHINGS		623	412	1,042	*				
EXPENDITURE TOTALS	15,151	77,130	11,962	104,243	*				
-----REVENUE SOURCES-----									
30110 (A) BEG. UNENCUMBERED FUND BAL		77,130		77,130	*				
36700 (A) CONT & DONAT/PRIVATE SRCE			11,962	11,962	*				
PRIOR YRS REV	15,151			15,151	*				
REVENUE TOTALS	15,151	77,130	11,962	104,243	*				
REVENUE AVAILABLE	89,092	REVENUE PENDING	0		*				